



INNIEUWSTEIN
Trade & Metal Services v.o.f.

Kreeft 4
4401 NZ Yerseke (Nederland)
Postbus 16
4400 AA Yerseke (Nederland)
Tel.: +31 (0)113-57 38 78
Fax: +31 (0)113-57 39 78
Internet: www.metalservices.nl
E-mail: info@metalservices.nl

CAST IRON GATE VALVE PN10



Size : DN 40 to DN 300
Ends : Flanges GN10
Min Temperature : - 10°C
Max Temperature : + 90°C
Max Pressure : 10 Bars up to DN150
Specifications : Rotating non rising stem and handwheel
Inside screw stem
Brass seat

Materials : Cast iron body



CAST IRON GATE VALVE PN10

SPECIFICATIONS :

- Single wedge disc
- Rotating non rising stem and handwheel
- Inside screw stem
- Graphite packing
- Brass seat
- Flanges R.F. GN10

USE :

- For common fluids
- Min and max Temperature Ts : - 10°C to + 90°C
- Max Pressure PN : 10 bars up to DN150 and 6 bars from DN200 to DN300

RANGE :

- Cast iron body flanged R.F. GN10 Ref. 150 from DN 40 to DN 300



MATERIALS :

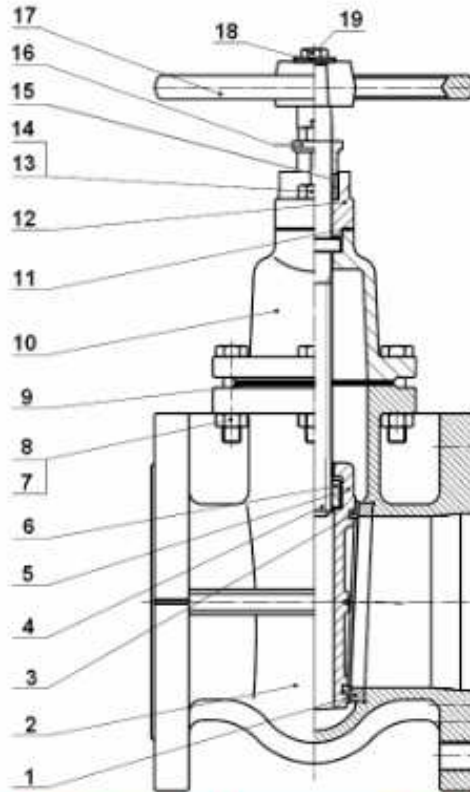

Item	Designation	Materials
1	Body seat	Brass
2	Body	Cast iron EN GJL-250
3	Wedge seat ring	Brass
4	Stem	SS 420
5	Wedge disc	Cast iron EN GJL-250
6	Stem nut	Brass
7	Bolt	Steel RSt37-2 (1.0038)
8	Nut	Steel RSt37-2 (1.0038)
9	Bonnet gasket	Graphite
10	Bonnet	Cast iron EN GJL-250
11	Stuffing box gasket	Graphite
12	Stuffing box	Ductile iron EN GJS-500-7
13	Bolt	Steel RSt37-2 (1.0038)
14	Nut	Steel RSt37-2 (1.0038)
15	Packing	Graphite
16	Gland follower	Ductile iron EN GJS-500-7
17	Handwheel	Cast iron EN GJL-250
18	Washer	Steel RSt37-2 (1.0038)
19	Bolt	Steel RSt37-2 (1.0038)



SIZE (in mm) :

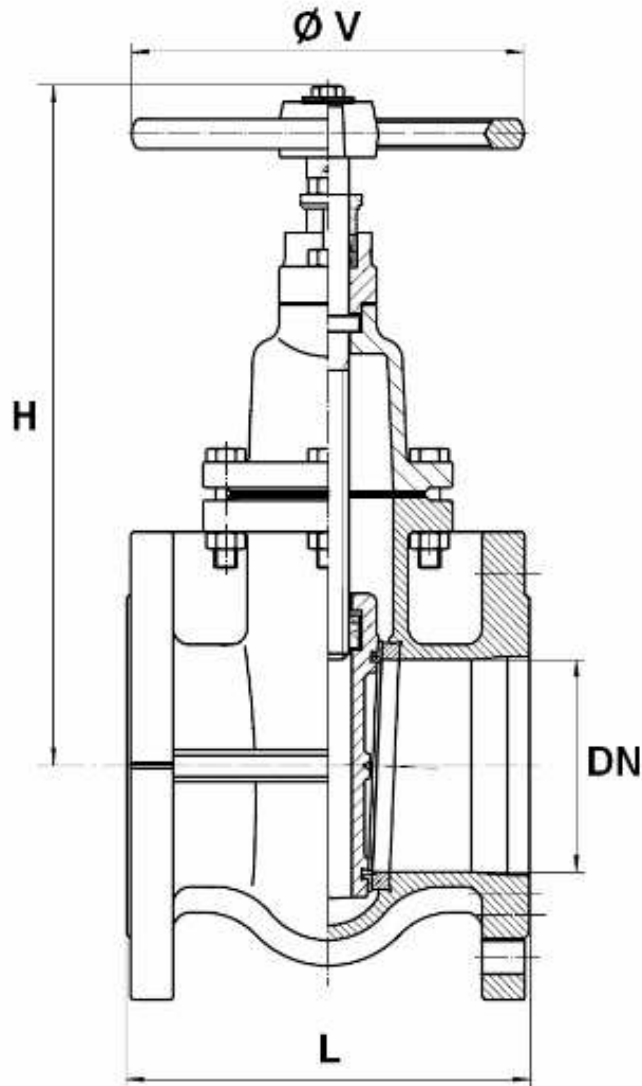

REF.	DN	40	50	65	80	100	125	150	200	250	300
150	L	140	150	170	180	190	200	210	230	250	270
	H	245	255	277	303	340	387	454	538	629	730
	Ø V	130	130	130	150	185	185	195	225	245	285
	Weight (Kg)	9.3	11.2	14	18.8	25	35.5	47	68	139	160



INNIEEUWSTEIN

Trade & Metal Services v.o.f.

Kreeft 4
4401 NZ Yerseke (Nederland)
Postbus 16
4400 AA Yerseke (Nederland)
Tel.: +31 (0)113-57 38 78
Fax: +31 (0)113-57 39 78
Internet: www.metalservices.nl
E-mail: info@metalservices.nl

STANDARDS :

- Fabrication according to ISO 9001 :2000
- DIRECTIVE 97/23/CE : Products excluded from directive (Article 1, § 3.2)
- Length according to EN 558-1 serie 14 (DIN 3202 F4)
- Flanged R.F. according to EN 1092-2 PN10
- Designing according to DIN 3352

ADVICE : Our opinion and our advice are not guaranteed and SFERACO shall not be liable for the consequences of damages.
The customer must check the right choice of the products with the real service conditions.